



INTERNATIONAL
SOURCE FOR
ERGONOMICS

A  COMPANY



61701664
(6170D & 6421D)

61701664

6170D Classic Lever Arm
with 6421D Keyboard
Tray with Slide-Through
Mousing Surface

Features	Benefits
Classic design includes locking lever and pull latch tilt release	Separate height and tilt adjustment controls provides intuitive adjustment
17" long ball bearing storage track	Provides precision storage under desk surface
21" W x 10.5" D rugged ABS tray assembly with built-in palm rest and anti-slip mat	Ample room for keyboard, with built-in palm rest for ergonomic comfort
MDF slide-through mousing surface	Allows for storage and ambidextrous mousing
Comes with all mounting hardware for track and keyboard tray mounting	Easy assembly of product and simple attachment to desk, with basic tools
Rugged construction	Manufactured in the USA. Tested to ANSI/BIFMA Standards.

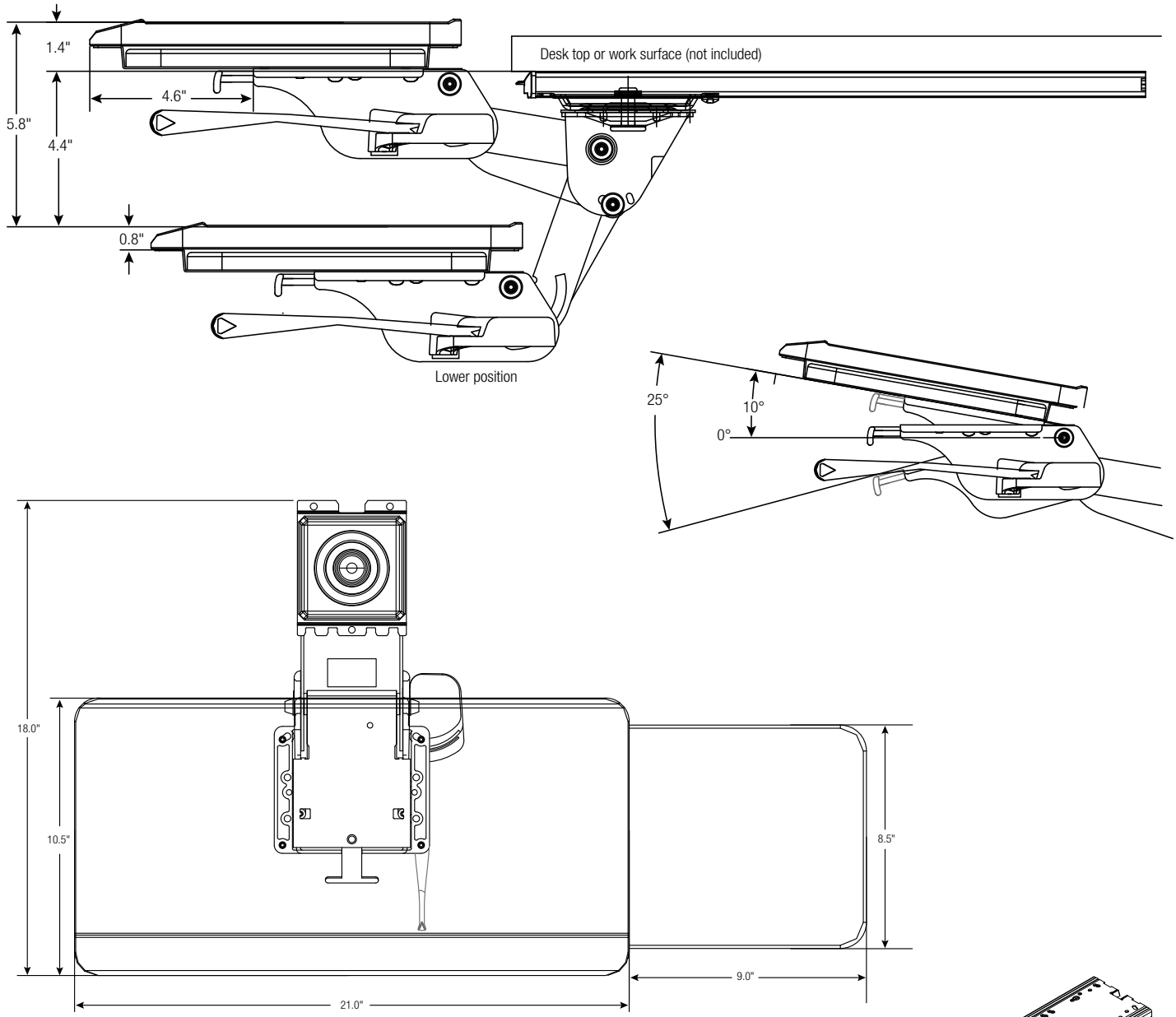

61701664

6170D Classic Lever Arm with 6421D Keyboard Tray with Slide-Through Mousing Surface

Ancillary Products:

- Use with ISE CPU Holders
- For Flat Panel Displays use the ISE Concerto or Xtend series of monitor supports

Model	Keyboard Tray Width	Keyboard Tray Depth	Height Above Track	Height Below Track	Track Length	Weight
61701664	21.0"	10.5"	1.4"	4.4"	17"	11.22 lbs.

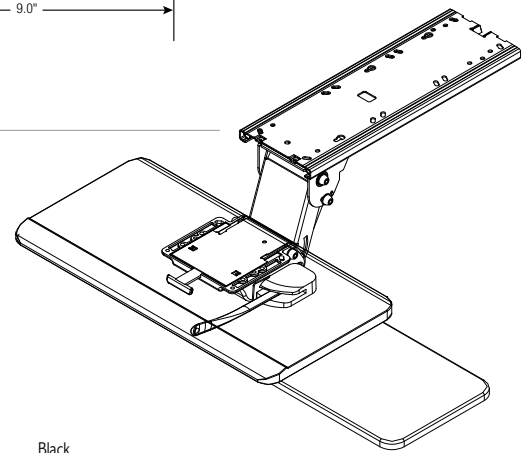

Black



Code Compliance: Exceeds ANSI/BIFMA standards

Notes: 1. Weight = packaged shipping weight per unit. 2. Specifications are subject to change without notice.



950 Warden Avenue
 Toronto, Ontario, M1L 4E3
 1.800.837.8640
www.ise-ergonomics.com

A  COMPANY

ISE reserves the right to change product specifications at any time without notice and without incurring responsibility for existing units.
 ©2022 ISE International Source for Ergonomics.

OL2821-A/1122