



INTERNATIONAL
SOURCE FOR
ERGONOMICS

A  COMPANY



Xtend Dual Monitor Arm

ISE introduces the Xtend Dual monitor arm. Enjoy all the same features and benefits of Xtend plus dual monitor use. Utilizing a dual cross bar, users experience simultaneous, parabolic viewing of 2 monitors together at an economical price. Its tool-less thumb knobs make installation and adjustments quick and easy.

7822J02 Series

Features & Benefits

Best in class arm provides 26.0" of reach with 13.0" of usable height adjustment.

Visually appealing pole-less monitor arm folds into a 4-3/8" area for more desk space in smaller work environments.

Tool-less clamp installation makes assembly quick and easy.

Flexibility and more options for the end user with a simple, easy-to-use Allen wrench adjustment to counterbalance the weight of the monitor.

With a clamping range of 0" to 2.40" (clamp) that is standard for the Xtend, this new arm will fit to any work surface.

Enclosed cable management system hides cables

Counterbalanced spring technology allows for 2 to 20 lbs load maximum (max 10 lbs per screen)

Clamp and grommet mounting options.

Dual Crossbar holds monitors up to 22.0" horizontal width each.

Preset 15° parabolic array provides easier viewing, reducing eye strain.

Adjustable face plates with tool-less thumb knobs for quick and easy adjustments & installation

The arm swivels 360° around the base, increasing the options for display position.

Choice of colors – silver, white or black

Made in USA- TAA compliant. Meets GSA bid requirement.

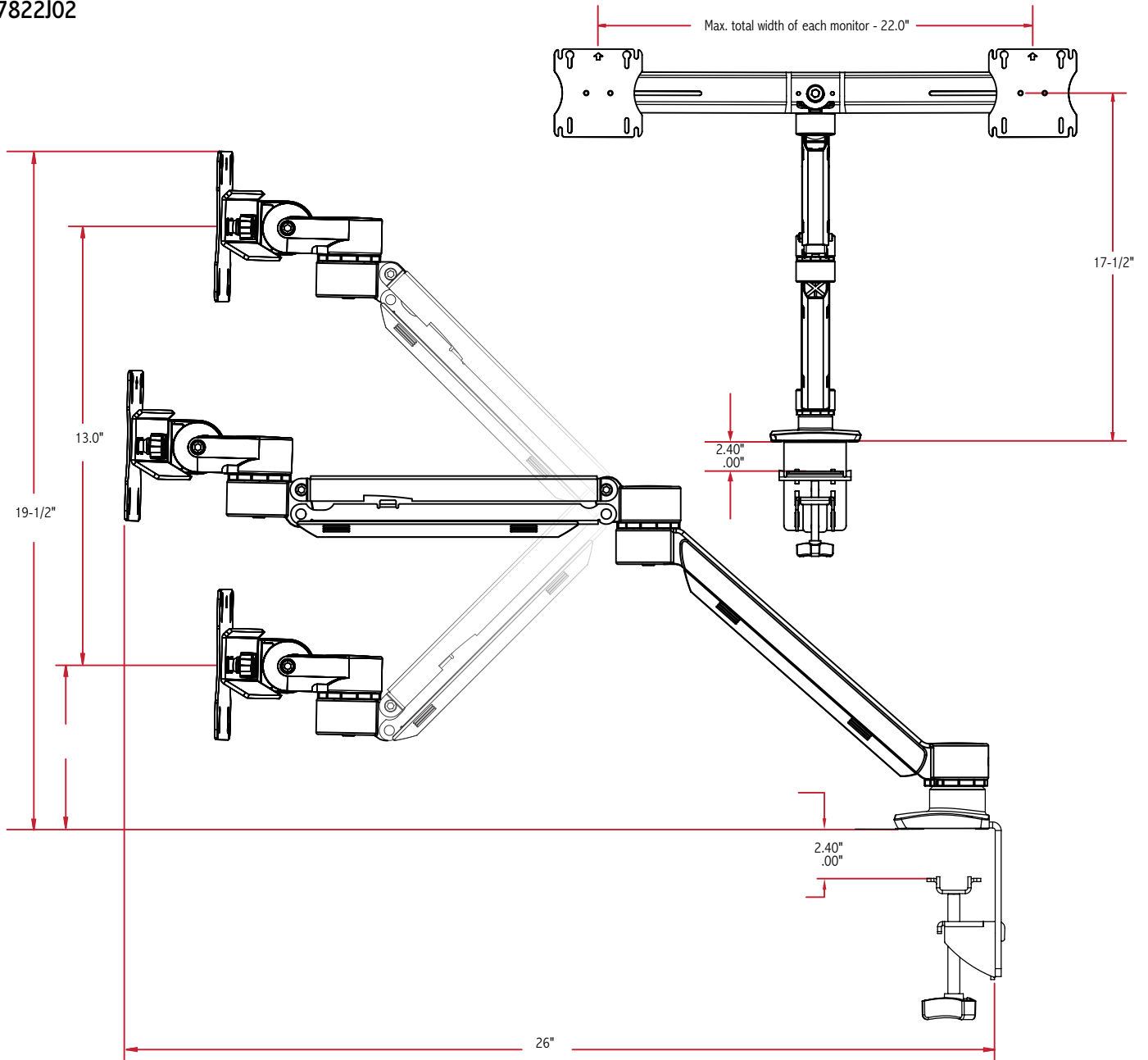

Xtend Dual Monitor Arm 7822J02 Series

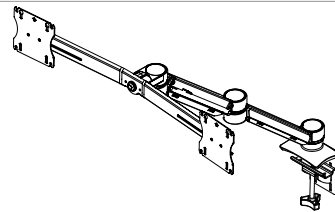

Model	Colour	Weight	Description
7822SJ02	Silver	9.4 lbs	Two screen, dual extension cross bar with one height-adjustable segment
7822BJ02	Black	9.4 lbs	Two screen, dual extension cross bar with one height-adjustable segment
7822WJ02	White	9.4 lbs	Two screen, dual extension cross bar with one height-adjustable segment



Notes: 1. Weight = packaged shipping weight per unit. 2. Specifications are subject to change without notice.